

GRCC

M A G A Z I N E

News from Grand Rapids Community College

Fall 2009



Success is Fundamental at GRCC's Learning Corners

Sneden Hall Doors Open to 1200 Students
(Just in Time!)

Wind Power Collaborative:
The Sky's Not the Limit

ENDER TWIN BOWL I IS COMING!



A Note From the President

Fall classes are now underway and I have to tell you that I am very excited by what I see. The work achieved by our staff this past summer has been nothing short of amazing. Some classrooms have been moved, while others were renovated, and with the addition of Sneden Hall, we've added a whole new classroom building – take a “tour” on page 8. All of this work was done in anticipation of one very big change here at GRCC: 17,000 students have enrolled for Fall classes, our highest enrollment ever, 10% higher than just one year ago.

I see this as a good thing. We have not turned away any first-year, full-time students this year which means we are meeting community demand – and our mission as a community college.

When I read my first copy of GRCC Magazine, I was still in Pennsylvania, in the process of moving to Grand Rapids, and, frankly, it made me proud. This issue is no different. In the pages to follow, you will read about programs and events that will impact the community we live in, maybe even you personally, such as GRCC's role in bringing wind energy jobs to Grand Rapids. The story on Arlisha James, a current student at one of our Learning Corners is an excellent example of how we can transition students to college.

You'll also see a listing of the many events taking place on campus in October, one of which is very near to my heart: The “Twin Bowl,” a football game where GRCC's football team will likely beat the football team from Harper College, where my twin brother is president. This should be a great game, and I invite you all to come and root for the Raiders!

Enjoy the Fall season, and this edition of GRCC Magazine.

Warm regards,

A handwritten signature in black ink, appearing to read 'S. Ender', written in a cursive style.

Steven C. Ender, Ed.D.
President, Grand Rapids Community College



On the Cover:

A brighter future? It's not a problem for Arlisha James, who overcame tough times and is now working towards her college degree at the GRCC Learning Corner at Wealthy.

Photo by Mitch Ranger Photography



4 Campus Update

Command performances from Actors' Theatre alums

Energy savings program producing results

Military magazine salutes G.I.-friendly service

Green Building Council at home with GRCC

International ArtPrize competition draws support

6 Arlisha's Story

Learning Corner turns out to be the right move

8 The Kids in the Hall

Snedden Hall opening is Phase I in GRCC's expanding space program

14 Winds of Change

GRCC part of a ground-breaking collaborative to bring energy industry to Michigan



16 Working the Earth

"Tilling to Table" group promotes virtues and value of hands-on food production



18 Full Steam Ahead

Tooling lab students expand capabilities by building miniature engines

20 Foundation News

A prescription for fund-raising fun and Twin Bowl smack talk

20 October Calendar

Make plans for a month to remember

22 GRCC Newsmakers

Appointments Awards and honors

GRCC Magazine is published three times per year by the Grand Rapids Community College Communications Department and Print Solutions.

143 Bostwick Avenue
Grand Rapids, MI 49503-3295

Editor:
Nancy O'Brien

Managing Editor:
Vicki Hudson

Contributing Writers:
Vicki Hudson
G.F. Korreek
Klaas Kwant

Layout & Design:
Amanda Cook

Photography:
Derek Devries
Vicki Hudson
Klaas Kwant
Mitch Ranger Photography

This publication is printed on 10% post-consumer recycled paper.

© 2009 Grand Rapids Community College

Grand Rapids Community College is an equal opportunity institution. GRCC is a tobacco free campus. 150861 9/09

mission

It is the mission of Grand Rapids Community College to provide the community with learning opportunities that enable people to achieve their goals.

vision

Grand Rapids Community College is a vibrant institution of higher education dedicated to enriching people's lives and contributing to the vitality of the community.

values

R Responsiveness
A Accountability
I Innovation
D Diversity
E Excellence
R Respectfulness
S Service

Actors' Theatre Continues To Produce Star Performers



Rodney Vaccaro

Actors' Theatre has been affiliated with GRCC since its founding by theater department faculty member Fred Sebuslke in 1980. Throughout its history Actors' Theatre has supported the talents of fledgling and veteran performers through classes, workshops, and a yearly series of ambitious and enlightening performances at the Spectrum Theater. The organization also supports its performers by paying a small stipend for performances, something few theaters in Grand Rapids provide.

The success of Actors' Theatre alumni is further evidence of its success. Here is an update on just a few taking recent curtain calls:



Ryan Jarosch

- **Ryan Jarosch** — an alumnus of the Actors' stage — was nominated in 2009 for the prestigious JEFF Awards, given for outstanding performances in the Chicago area.
- **Gregory Jbara** — who performed last year in "Duets," an Actors' fundraiser — won a Tony award for his work in "BILLY ELLIOT the Musical."
- **Teresa Thome & Patrick Ziegler** — Actors' alumni in performing, writing and directing — won an Emmy award for "Come On Over," an original children's television series.
- **Laurie Veldheer & Chelsea Swanderski** — alumni of Actors' stage — have both been a part of the national tour of the musical "Hairspray."



Sammy Publes

- **Rodney Vaccaro** — writer, director and actor — won an Emmy award for "Run The Wild Fields," an adaptation of the play "Home Of The Brave," which premiered at Actors' Theatre.
- **Sammy Publes** — former theatre student/GRCC alum — was recently cast in a film starring Robert DeNiro.
- GRCC alum **Brian Miller** was in Grand Rapids in the Spring of 2009 for the production of a movie starring 50 Cent. Miller and his crew used Spectrum Theater for some of their rehearsals before they began filming.

GRCC Earns High Rank for Service to Military Students

GRCC is ranked among the top 15% of the nation's "military-friendly schools" by *G. I. Jobs* magazine. The listing is posted in the magazine's September 2009 "Guide To Military Friendly Schools" and on a website by the same name.

The college was honored with a plaque noting its high service

standards and a letter of commendation from Rich McCormack, publisher of *G. I. Jobs* magazine.

GRCC Registrar Howard Shanken reported the college has been a long-time supporter of military students.

"These men and women have a lot of paperwork and deadlines that, over the years, GRCC has learned to

accommodate and even facilitate," Shanken acknowledged.

Janet Chesla, who specializes in serving veterans applying to GRCC, added that the college continues to monitor stories about the G.I. Bill so that, "we will be right on top of any changes that may come."

Energy Efforts Produce Six-Figure Savings

After just one year, GRCC's participation in the national Energy Education program has resulted in energy savings of more than a half million dollars. The trend is continuing for the current program year in spite of increased physical plant demands as a result of increased student enrollment.

GRCC President Dr. Steven Ender continues to remind audiences that saving every dollar is always important — not just in tough economic times: "This (program) is just one more way GRCC can show the public that we are pursuing every possible method to improve cost efficiency at the college."

GRCC ENERGY SAVINGS

June 2008 - May 2009

Cost without Energy Management.....\$2,797,759
(what GRCC would have spent before instituting energy savings practices)

Actual Cost with Energy Management.....\$2,371,598

Cost Avoidance 15.2%.....\$426,161

Savings from new practices beyond Energy Ed program.....\$138,841

Total Savings\$565,002

Green Building Council Finds Home in GRCC Tassell M-TEC

As interest and involvement in green building continues, so does the demand for more programs and services. The West Michigan chapter of the U.S. Green Building Council had been operating out of space in its executive director's home since 2004, but as its membership doubled in size over a two-year period the organization needed room to grow...and fast.

The GRCC Tassell M-TEC facility provided a solution. The USGBC moved in with GRCC last June and the relationship is flourishing.

Brian Shultz, construction trades manager of GRCC's Tassell M-TEC and a USGBC board member, was involved in the discussion and support of the idea. Linda Frey, the USGBC's executive director, explained: "We function with an eye toward partnerships and collaborations. When he found there was support for us from GRCC to take a space, we decided to make the move."

The new space provides room for up to four workers and provides access to Tassell M-TEC conference rooms.

GRCC Plays Host To International ArtPrize Competition



Fisher Stolz

ArtPrize, one of the largest art competitions ever is headquartered in Grand Rapids and GRCC is one of the many installation venues throughout the community. The College features the work of three artists who, in addition to displaying their work, conducted a panel discussion with students and area residents.

ArtPrize is open to artists from around the world and features \$450,000 in awards. The competition finishes its run with final voting in October. Over 1,200 artists are showing their work at over 150 venues in the Grand Rapids area.

Artists hosted by GRCC are:

- **Fisher Stolz**, featuring "Moonbench," a steel and marble sculpture, installed at the south end of Bostwick Commons
- **Charles Thompson**, whose 2-D relief sculpture mural appears in Bostwick Commons across from GRCC's Main Building
- **Richard Burns**, featuring a metal kinetic sculpture, "Wind Balance #1," showing at the Heritage Restaurant Patio
(no photo available)



Charles Thompson

Life Takes Turn for the Better at GRCC Learning Corners

by Vicki Hudson

Arlisha James stands out among the rows of students around her. She's got a big smile on her face. She likes her math class at GRCC's Learning Corner at Wealthy for a lot of reasons, but mainly because she's making her own way in life. When she graduated from her GED class last summer, Arlisha had already surpassed her parents' high school education. But she knows Dave Selmon, current director of GRCC's Learning Corners on Grand Rapids' East and West sides, is right when he says that completing a GED, the equivalent to finishing high school, is not an end.



Arlisha and her math teacher, Mary Lenaway, share in Arlisha's success.

"We have a graduation and we're proud of those that complete their GED, but after the celebration, I want them to keep right on going until they get a college degree," says Selmon.

"Mr. Selmon, he stays on me," says Arlisha, adding "he was my principal when I was in kindergarten at Sigsbee." Sigsbee Elementary School sits less than a block away from the Learning Corner in the same neighborhood where Alisha grew up.

Growing Up Tough... and Stronger

Some would say Arlisha's life story is all too familiar: In her own words she "grew up tough" in a home on Baxter Avenue that was frequently without lights or heat. She went from Sigsbee to Iroquois Middle School, but then, she says, "You know, I got in to some trouble and ended up at an alternative school." Then she had a baby, attended Park School for pregnant high school students, and... dropped out.

The next chapter in this energetic, outgoing 25-year-old's life includes being emancipated from her home, the birth of a second daughter, and a 2-year stint at McDonald's. No one knew better than Arlisha where this all was heading. But Arlisha decided her story would have a happy ending.

First she got help in finding an apartment and getting the things needed to put together a home for herself and her children. She then found an agency that offered courses in money management and how to conduct a job search. "I just always knew I needed education," she says.

"My mom and dad – even though they had their own problems – they kept telling me 'get your education.'"

Fast forward to July 2009. Arlisha has finished one of three sections needed to complete her GED. Her mom has cancer and needed Arlisha's help. It wasn't long before Theresa Williams, the soft spoken secretary at the Learning Corner, realized the popular student had gone missing.



Arlisha James is charting a new life course with help from the GRCC Learning Corner.

"She called me up," says Arlisha, still a bit surprised. "She told me they missed me!"

"I wanted to graduate. Ms. Williams told me the graduation was the next day! I still had two tests to pass, but I wanted to do it," says Arlisha. "I took the two tests that day and Ms. Williams called to say I had passed both on the morning of graduation day. So that night I got my GED with my class."

GRCC Provost Gilda Gely says, "Arlisha and all the others like her are exactly why we started these Learning Corners. We come right into the neighborhoods where people who don't think of themselves as "college material" will feel comfortable."

"We believe that given the right circumstances anyone can learn," Gely adds. "Our mission is to provide those learning opportunities."

“We believe that given the right circumstances anyone can learn,” Gely adds. “Our mission is to provide those learning opportunities.”

- GRCC Provost Gilda Gely

Learning Corner Committed to Going the Distance

Learning Corners offer small classes in GED completion and in college readiness, as well as a very supportive environment where students can get the personal attention that they need to build confidence as well as study skills – “whatever it takes” according to Selmon, to make the students successful.

Again, Arlisha’s a model for GRCC’s efforts. She is at the Learning Corner taking pre-college math, but she has crossed that psychological bridge and now feels at home in her Communications and English classes on GRCC’s main campus as well.

GRCC seeks out partnerships to strengthen and broaden many of their programs and their Learning Corners are no exception. The Learning Corner @ Wealthy, where Arlisha attends, partners with The West Michigan Literacy Center and benefits from its proximity to a Huntington Bank branch. If a prospective student needs to restart their education at a level below the GED, the Literacy Center can step in and build fundamental reading skills. If students want training in life skills, such as money management or financial literacy, Huntington makes instructors available at the bank branch and in the Learning Corner classrooms.

Across town, at GRCC’s West Side Learning Corner, Lake Michigan Credit Union made room in their



David Selmon, director of GRCC's Learning Corners, keeps students energized and focused.

beautifully renovated space in the historic Kindel Furniture Factory. There the partners reach out to the neighborhood residents with a mostly bilingual staff and instructors and the same emphasis on personalized attention. When Lorena Aguayo-Marquez, the Center’s educational support person, and Selmon talk about student progress or needs, they both use first names. “We know our students,” she says, and Selmon nods as he strides off to conduct an orientation session for the new Fall classes.



Up on the Hill: GRCC's Sneden Hall First Launch in New Space Program



Opening day: the GRCC banner is proudly displayed as Sneden Hall opens its doors. (Sneden Hall is on the property purchased from Davenport University.)

***"It allows us to add learning space
in our most critical service areas."***

- Vicki Janowiak, Sneden Hall Project Coordinator

The weekend before the first classes were scheduled to begin at GRCC's Sneden Hall, not a single space was ready.

"It was full of dust, wiring...the fire marshal and work crews were passing each other in the halls. It didn't look like we were going to make it," recalls Vicki Janowiak, Interim Director of Space and Emergency Planning. Even so, Janowiak, who has all but lived at the site since the purchase agreement was reached with Davenport University in mid-June, wasn't worried. As a lead person in several building openings on campus, Janowiak has seen miracles, large and small, before. She had faith Sneden Hall would be ready.

She was right. The work got finished, dust cleared, and the students came. The only question left was which room to head to for each class. After one week, Sneden Hall was serving 85 class sections and 1,200 students.

The bigger news is that Sneden Hall marks phase one of a long-term program to optimize the former Davenport space and incorporate it with GRCC. And from the moment the first class began, the payback has been obvious.

More Room for Students and Classes

“It allows us to add learning space in our most critical service areas,” says Janowiak. “We were landlocked before, and had few options. But we’ve been able to add 85 class sections serving 1,200 students because of this new location.”

The move to accelerate re-development of the former Davenport University site came in response to incoming President Steven C. Ender’s commitment to serving everyone who wanted to attend the college.

“We had a short-term vision,” Janowiak explains. “We started talking after Dr. Ender challenged us not to turn anyone away. After we reached an agreement with Davenport, we toured the campus and began discussing how it might be used. We looked to see what space would work with minimal effort.”

It was agreed that Sneden Hall had the space that would work best.

This decision set numerous others in motion. As Rockford Construction and the GRCC facilities team got to work, Janowiak met with faculty and staff to determine what types of programs or classes would best suit the space. Operating hours were also important.

“We identified days when we had the greatest overload,” she recalls.

“Typically, it is Tuesday-Thursday from 10 to 2. We could provide some immediate relief here. We also decided we would not initially have Friday or evening classes.”

The construction work required a substantial time commitment. “There was ADA compliance, HVAC, wiring...” Janowiak says, running through a litany of tasks that needed to be completed. “Our IT people had to make sure we were completely connected with Lyon Street...we had to install new fire stop doors...we had to rewire and renetwork. There was cabling everywhere. But now



Sneden Hall represents the initial phase of the college’s long-term plan and provides room for 86 class sections and 750 students on a Monday through Thursday daytime schedule.

we have the same system as the rest of the college and we also coordinate via mail and other delivery systems.”

Despite the work, the project relieved some of the pressure the college was facing at its main downtown campus. One new building was in the planning stage and had just become a candidate for state funding.

“This acquisition changes that,” Janowiak says. “We’ve since resubmitted a plan to the state to transform Cook Hall into a health and math education center — from the second through fifth floors.”

Immediate and Long-Term Benefits

The Sneden Hall location offers a number of benefits beyond space.

“Windows,” Janowiak smiles. “Every classroom...and every office uses natural light. We now have green space...landscaping...windowed classrooms and offices. And we have a multi-purpose room for conferences and training. There’s already a waiting list.”

As yet, no department is completely housed at Sneden Hall. A variety of classes from all program curricula are offered. The exceptions are technical programs, life sciences and nursing, which require labs, equipment, and space not yet available.

Rick Olsen, Dean of Arts & Sciences, volunteered to move his office there and also serves as an ombudsman for Sneden Hall faculty. Olsen says, “The staff has access to everything they have at other GRCC locations — wireless, phones, work surfaces, and a large area with furniture that can be reconfigured to adapt to need.”

“Square footage is still at a premium everywhere,” he adds. “But the faculty here seem to like to meet with people from other departments.”

Olsen provides a survey for teachers to complete after each class to comment about the quality of the learning environment, “to see what works and what does not.”

The new space also creates opportunities to organize specific programs. Olsen points out, for example, that the college’s Career Advancement Program (CAP) now has a full-time, dedicated space.

Diane Patrick, Associate Dean of Enrollment Services, also sees opportunity in the Sneden Hall location. Four of the six divisions of her department are now located at Sneden, specifically those that deal with student recruitment.

—Continued on next page

“The setting is ideal for recruitment efforts...”

- Diane Patrick, Associate Dean of Enrollment Services



Rooms had to be gutted, rewired and connected with the existing GRCC campus.

“The setting is ideal for recruitment efforts, parent conference, tours...,” Patrick says. “It’s also perfect for the CLS (College Life Studies) program that all first-year students are encouraged to take. The spaces here fit a square-footage-to-participant ratio of 20-25 students, a good number for these classes.”



Renovation included providing an open, welcoming area for students to gather or study.

Places to Park, Ride... and Walk

Parking, always a campus issue, is readily available at Sneden Hall. While some spaces are initially reserved for Davenport staff — who will remain for a short transition period — there will eventually be over 500 spaces and, like other GRCC parking facilities, will feature Raider Card access. There is also shuttle service between buildings. The college has a one-year contract with The Rapid, which will provide service every 12 minutes and two stops along the way.

There is a nice neighborhood touch as well. Sneden Hall and the attendant grounds are part of a historic district and not far from GRCC’s McCabe-Marlowe House. The connection dovetails with the college’s upcoming centennial celebration.

Work has already begun on Sneden Hall’s third floor. In time, other buildings on the campus will be renovated and opened for classrooms and offices.



The new computer lab creates flexible learning options for the Career Advancement Program (CAP).

GRAND RAPIDS COMMUNITY COLLEGE FOUNDATION invites you to
Be a sponsor...be a guest...bring friends!



Rx for fun!

- + An Evening of Activities to Benefit the GRCC Nursing
- + Program
- + GRCC Wisner-Bottrall Applied Technology Center
- + Doors Open at 6:30 p.m.
- + Brief Program at 7:30 p.m.
- + Dress Casual

Tickets \$150 per person; sponsorships available

***Make your appointment today.
Call Ann Marie Birr at (616) 234-3939.***



Grand Rapids
Community
College

Nursing Programs

- 
- ✓ Take a "shot" with our Sim Man!
 - ✓ Are you REALLY germ-free?
 - ✓ Check your blood pressure.
 - ✓ Temperature raising cuisine!
 - ✓ Test tube cocktails.
 - ✓ Heart-pounding delicious desserts!



SECCHIA
INSTITUTE
FOR
CULINARY
EDUCATION
GRAND RAPIDS COMMUNITY COLLEGE

GRCC Joins Collaborative Effort to Bring Wind Energy Training Programs to West Michigan

West Michigan Community College Collaboration

Ferris State University, Big Rapids
Glen Oaks Community College, Centerville
Grand Rapids Community College
Grand Valley State University
Kalamazoo Valley Community College
Kellogg Community College, Battle Creek
Montcalm Community College, Sidney
Muskegon Community College
Northwestern Michigan College, Traverse City
West Shore Community College, Scottville

With a goal of producing a new generation of workers for the wind turbine industry, GRCC has joined with seven other community colleges and two universities to form a one-of-a-kind collaborative. The group, known as the West Michigan Community College Collaboration, has developed a business plan and is in the process of pursuing funding and space for phase one of what the participants expect to be a long-range alternative energy training program.

Julie Parks, GRCC's director of workforce development, says the collaboration is not only unique to the state, but quite likely the country.

"It's the first time in West Michigan all the colleges have been working together on a major project," Parks says. "Were very open, very transparent about our work. As far as I know there's nothing like this in the U.S."

The collaboration's efforts will begin with wind energy, a technology in which West Michigan — with its extensive coastline

and experienced industrial workforce — is expected to be at the forefront. The Michigan Wind Energy Resource Zone Board — a group formed by law in 2008 and appointed by the Michigan Public Service Commission (PSC) — recently issued a preliminary report that identified four regions in the state as being suitable wind energy resource zones. Three of them are located in West Michigan. A series of public hearings will determine which regions are further developed.

In the meantime, the collaboration is laying the groundwork for training the people who will bring wind energy to their communities.

Parks says the project has been underway for more than a year. "Our involvement began at the urging of The Right Place (West Michigan's largest non-profit economic development group)," Parks recalls. "We began investigating options and saw that wind was a good starting point."

Wind energy remains an emerging technology. It has gotten considerable news coverage in recent years, including a national promotional campaign

fronted by oilman T. Boone Pickens. Wind application has also increased. According to the American Wind Energy Association, wind generating capacity doubled in 2008.

The Collaboration Takes Shape

That same year GRCC met with other colleges to form the collaboration at GVSU's Merritt Center in Muskegon. The group outlined its goals and established a business plan. Members from industry were also invited to participate.

"It is important that we have employers at the table with us," Parks explains. "They benefit from a trained workforce, but they also gain product development opportunities...our programs become working classrooms."

In addition to involving employers, the collaboration reached out to other alternative energy groups.

"We also met with NextEnergy in Detroit (a nonprofit group advancing alternative and renewable energy initiatives on the east side of the state.)," Parks reports. "This is not just a west side initiative.

More than 8,500 megawatts of new generating capacity were installed in the United States in 2008, an increase in capacity of 50 percent. It was estimated the added capacity would be enough to power more than 2 million homes.

Source: The American Wind Energy Association

Even though West Michigan is lauded for its well-trained industrial workforce, and most colleges in the collaboration already teach industrial manufacturing skills, the wind industry will still require specialized training — such as the ability to manage turbine installation and maintenance, both at the residential and utility level. This means expanded math and science training and more background in working with the exotic materials used in energy equipment.

While there is no universal collaboration program, a number of the institutions already offer coursework in alternative energy.

GVSU and Ferris State have instructional courses. Muskegon Community College offers an introductory alternative energy course. Montcalm Community College provides classes in solar application. GRCC has recently initiated a wind energy study course through its continuing education division. And Kalamazoo College has a wind technology training program.

Commercial wind turbine sites operating in Michigan:

- Michigan Wind 1, located in the Thumb area and owned by John Deere Wind Energy; 46 turbines with a capacity of 69 megawatts (MW).
- Stoney Corners Wind Farm, Missaukee County, owned by Heritage Sustainable Energy; two turbines producing 5 MW.
- Traverse City Light and Power; one turbine producing .6 MW.
- Harvest Wind Farm, also headquartered in the Thumb and owned by John Deere Wind Energy; 32 turbines producing almost 53 MW.
- Mackinaw City Wind Power, owned by Crystal Flash Energy; two turbines producing 1.8 MW.

Source: The Michigan Wind Energy Resource Zone Board

Maintaining Continuity

Ultimately, the collaboration will serve as both a clearing house and organizing force for energy training. It is anticipated The community colleges would offer classes leading to an alternative energy certificate or to a two-year associate's degree that could be extended to a four-year college degree.

But the major component of the program is to develop a wind turbine site and renewable energy center for hands-on training. According to Parks, a wind energy training program demands significant space and financial commitment.

“There are 8,000 pieces in a turbine,” she explains. “We’ll need hands-on training. It will require space....a 300-foot training tower— you’ll have to be able to go up on that if you’re going to work in this industry We’re also going to need equipment and to start setting up internships with energy companies.”

The center would be a destination for students coming from programs at their local college. “With the collaboration, students could do on-line classroom work anywhere before going to the training center,” Parks says.

Parks reports that the collaboration is looking for a

50- to 60-acre parcel of land. It may have a small head start. The GVSU Michigan Alternative and Renewable Energy Center in Muskegon has been granted \$1.4 million in federal funds to develop an off-shore, water-based turbine demonstration project on Muskegon Lake. The area is one which the collaboration is considering for its site. It is estimated the project will cost close to \$17 billion by its completion. The collaboration has already talked with state officials about funding options.

While the price tag may seem high, the opportunities are already here. At least five companies are providing commercial wind-generated power throughout the state. In addition, a major new alternative energy partnership has been formed in West Michigan. Rockford Construction has joined forces with the internationally-based Bergé (pronounced Ber-hay) Logistica Energética, and the MAPA Group — a business development firm — to form Rockford Bergé, a single-source provider of wind farm infrastructure construction and logistics.

“There are over 1,000 jobs out there already,” Parks says. “And a lot of them are just taking the skills people already have and reemploying them.”

Michigan Wind Energy Zones

Counties within the four regions designated by The Michigan Wind Energy Resource Zone Board preliminary report include:

WEST MICHIGAN

Allegan
Antrim
Benzie
Charlevoix
Leelanau
Manistee

THUMB AREA

Bay
Huron
Saginaw
Sanilac
Tuscola

Source: The Michigan Wind Energy Resource Zone Board

The Whole Earth In Their Hands

GRCC Food Group Promotes Benefits of Gardening From Scratch



Committed culinary arts students now grow their own vegetables and herbs at sites throughout the city, including the GRCC Foundation's McCabe-Marlowe House.



“How do carrots grow...on a tree, on a bush in the ground or what?”

When a culinary classmate asked GRCC Culinary student Jana Deppe that question, she knew what she had to do: She would gather fellow culinary students to start a community garden and show that student.

That was the seed that planted the idea for the initiative called “Tilling To Table,” a group made up of fellow culinary students at GRCC and community members that now maintains a herb garden and a vegetable garden at the college. With the help of GRCC faculty James Muth and Department Head Randy Sahajdack, food grown on campus is used in the restaurants the GRCC’s Secchia Institute for Culinary Arts students use as working classrooms.

“We want people to join us,” Deppe says, about the newly established non-profit that gets people in touch with local food sources. Another group member Danielle Chilvere, says, “we want to be active in our community and we want the community to be active in this group.”

Staying Connected to Our Food Sources

“We, as a society, have become so disconnected from where food comes from,” says Deppe.

“Tilling to Table wants to be active in our local food system. We want our hands in the dirt. We want to know what seeds farmers are planting...and where and how.”

The group meets weekly and has already worked with The Blandford Nature Center’s Youth Farm Team . “We rented a kitchen for the day and cooked with them,” says Deppe. “We wanted to provide a capstone experience to what they had learned about growing food by now preparing dishes from the foods they had harvested.” In addition to working with Blandford Nature Center, the Tilling To Table group has

worked alongside residents of Ransom Towers to maintain a community garden space with Heartside Gardeners, and helped out at Groundswell Community Farm in Zeeland. They also work with Lubbers Farms on some educational and catered events.

Tim Fritsch, a second year student in GRCC’s Secchia Institute for Culinary Arts, can articulate exactly why he wanted to be involved with Tilling To Table. “Working in the garden gives such a sense of purpose,” he says. “It may sound a little dramatic, but I like the responsibility of the work; I feel real ownership of what we are doing.”

“We want people to know the value of eating whole foods, that they too can grow beautiful heirloom foods in gardens, and be more connected to our local Grand Rapids food system” says Deppe.

“Working in the garden gives such a sense of purpose.”

- Jana Deppe

Founding Tilling to Table member Jana Deppe surveys the rooftop garden at the GRCC Applied Technology Center.



Picking Up Steam: Tooling Lab Students Take Giant Strides with Small Projects

by Klaas Kwant

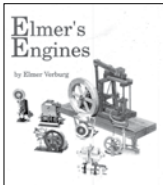

The challenge that student Ervin Sadler faced is an all-too-familiar one:

“I worked at Steelcase for 24 years and, due to outsourcing and downsizing, I had the opportunity to take an early buy-out and along with that, I had a chance to take schooling at GRCC, and I thought, well, if you’re going to lose your job, you might as well look to the future and find something better.”

Looking to the future, it turned out, required learning from the past, a history that includes GRCC Alumni, access to the Tooling Lab, and miniature steam engines.

Yes, steam engines: miniature versions of functioning, full-sized motors from around the world, built from designs drafted by Elmer Verburg and compiled in the book “Elmer’s Engines” (Old Orchard Publishing, c.1988). Verburg, a former machinist from Cedar Springs, attended Davis Technical High School in the 1940s, the school whose building would eventually

become GRCC’s Main Building. His book, which today is a prized, collectible, out-of-print text, was recently harnessed by GRCC Tooling Professor Larry Pierson.

“The students involved in our tooling course had completed their objectives,” Pierson explains. “Two of them — Ervin Sadler and Trung Pham — were motivated to develop their skills even further, so I started them on these engines. And once they did the first one, each subsequent engine got more and more difficult.”



Trung Pham and Ervin Sadler took on the work of producing Elmer Verburg’s designs at the suggestion of Tooling Professor Larry Pierson.

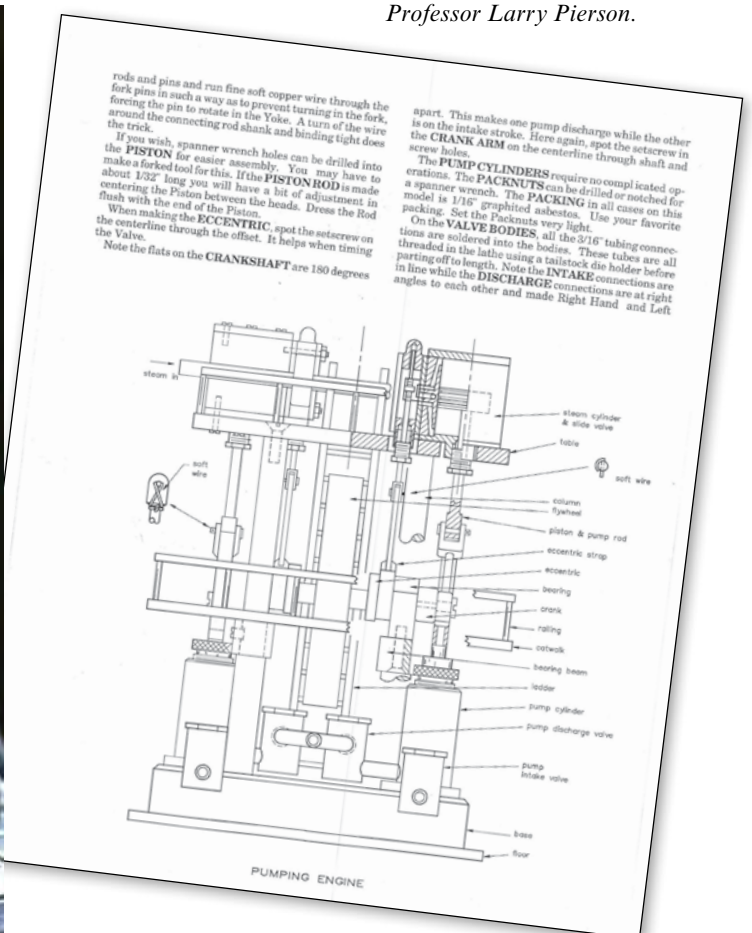

The Power to Stay on Course

The transition from doing line work at Steelcase to operating precision computer-controlled (CNC) machines doesn't happen overnight. But it does happen quickly under the talented direction of an instructor like Pierson. According to Sadler, "Larry showed us. That really says a lot: take someone without any background in running a machine, and then within two or three months have someone who is capable of building these types of engines, that's quite a credit."

To date, Sadler and Pham have made 12 fully operational engines (viewable on GRCC's YouTube Channel at www.youtube.com/grcc). Driven in the lab by compressed air, every wheel and piston moves exactly as designed, reflecting the quality of their learning as well as the care and passion both students possess. And there's no better judge than Verburg's son, Ralph, who visited the lab to see the engines... and is yet another GRCC Alumnus.

"If my father were still alive, he would be very pleased," Verburg says. "They are beautiful engines; I would say they're show pieces. In fact they all work,

even the little pump will pump water; it's beautiful."

Ralph Verburg carried on the family tradition of working in technical fields based on training he received from GRCC. "I was a student here in the fall of 64 through 66, in the electronics technology program," he recalls. "I came back for a hydraulics program in the ATC, and several computer programming classes and a linear electronics program. I think it's a wonderful school. I had good instructors, good courses; I think it's top notch."

Ralph values in particular seeing his father's work used in the way it was intended: "To me, it's very pleasing because I'm seeing all of his works, all of his efforts, to make something that people could use, enjoy and learn from. That's exactly what he would have wanted."

Trung Pham, who was laid-off from Behr Industries, values the opportunity to build something that works: "I feel very happy to see something really go, something from start to the end, knowing you got it right all the way in the process. It makes me feel very happy, very good. I built something myself."



Sadler and Pham are joined by Ralph Verburg, a GRCC Alumni, who enjoyed seeing his father's machines come to life.

Handwork and Thinking Skills Perfected

There are more than hands-on skills being displayed by Pham and Sadler. According to Pierson, "The skills involved include "higher level" critical thinking skills — how we interpret the print, choose materials, do the set-up, and run the machine tools to make those parts. And I think those skills are never going to go out of date."

Ralph Verburg agrees. "You've got to be able to look at something and figure out how to do it or solve it. We will always need people like that: someone who can build the first piece, be it electronic or in machining or chemistry."

Which means, of course, places like GRCC will always be needed to provide the opportunity for individuals to learn and excel, to cultivate an individual's passion.

"We're here waiting for Larry to unlock the door to start class in the morning," says Sadler. "And usually when it's time to leave, he's yelling, "Come on you guys! I want to go home! We'll stand there and eat our lunch while the machine's running while others take an hour for lunch...we look at that like it's an hour wasted that we could have had something else accomplished."

According to Larry Pierson, "They put an awful lot into this program, and they got an awful lot out of it."

This is a story that gets repeated, generation after generation, at GRCC.

They can be held in your hands, yet these miniature steam engines are fully functional. They are the designs of the late Elmer Verburg, a master machinist who attended Davis Technical High School, now GRCC's main building.



New Scholarships Highlight Community and Foundation Commitment

GRCC students, through the GRCC Foundation, have 290 scholarships available to them each year. During the last year, \$650,000 in scholarships were awarded to 880 students. And still, the need continues to exceed the capacity.

A primary focus of the Foundation this year is to continue providing new scholarship and grant programs for GRCC students. Thanks to the support of generous donors, a number of new scholarships have been created in recent months:

- West Michigan Plumber, Fitters and Service Trades Local Union No. 174 JATC (Joint Apprenticeship and Training Committee). A \$1,000 scholarship will be awarded to a GRCC student enrolled in the HVAC or Welding program. The student must have a minimum 3.0 GPA and live within the union's jurisdiction.

- Better Business Bureau Integrity Scholarship. Established by the Better Business Bureau of Western Michigan, this \$2,000 scholarship will be awarded to a sophomore, Michigan resident who has obtained at least a 2.0 GPA.

- CEBA Grant Fund. This scholarship was established by the GRCC Employees Benefit Association in response to President Enders "Giveback" request. Three \$1,000 scholarships will be awarded to students who are coming back to school to be retrained. This fund will assist them in purchasing tools and other resources needed for their specific program.

For more detailed information about these scholarships, please contact the Financial Aid Office or Foundation Office. For a list of other scholarship opportunities provided by the GRCC Foundation, please visit www.grcc.edu/financialaid.

Buildings for Success



GRCC's newly opened Sneden Hall

A GRCC Foundation priority for the coming year is to support GRCC's facility needs. We are in the planning stages of a campaign to support the renovation of the former Davenport University campus on Fulton Street. Sneden Hall is open for classes but there are additional opportunities available.

In addition, significant improvements to the Main Building, the Ford Field House, and Peter & Pat Cook Academic Hall are needed to provide classrooms, labs, and student spaces that support academic success.

GRCC Alumna Selected to Lead Alumni Efforts



Erin Cisler was recently promoted into the role of Alumni & Donor Relations Manager. In this new role she will be tasked with creating an alumni relations program at GRCC.

Dr. Andy Bowne, Associate Vice President for College Advancement, expressed confidence that Cisler can develop an alumni program that focuses on three areas:

- connecting alumni with each other
- connecting alumni back to GRCC for help on occupational advisory committees, student recruitment, guest speakers, and the like
- financial support for scholarships and other needs through the Foundation

"Erin has the qualities that we were looking for in someone to lead the alumni efforts." Bowne commented. "She loves GRCC and our students, she's done a great job with donors, and she's ready for the opportunity to develop a solid alumni program."

"Erin has the qualities that we were looking for in someone to lead the alumni efforts."

- Andy Bowne,
Associate Vice President
for College Advancement

Twin Bowl on Tap: A Battle From Beginning to End (Ender)

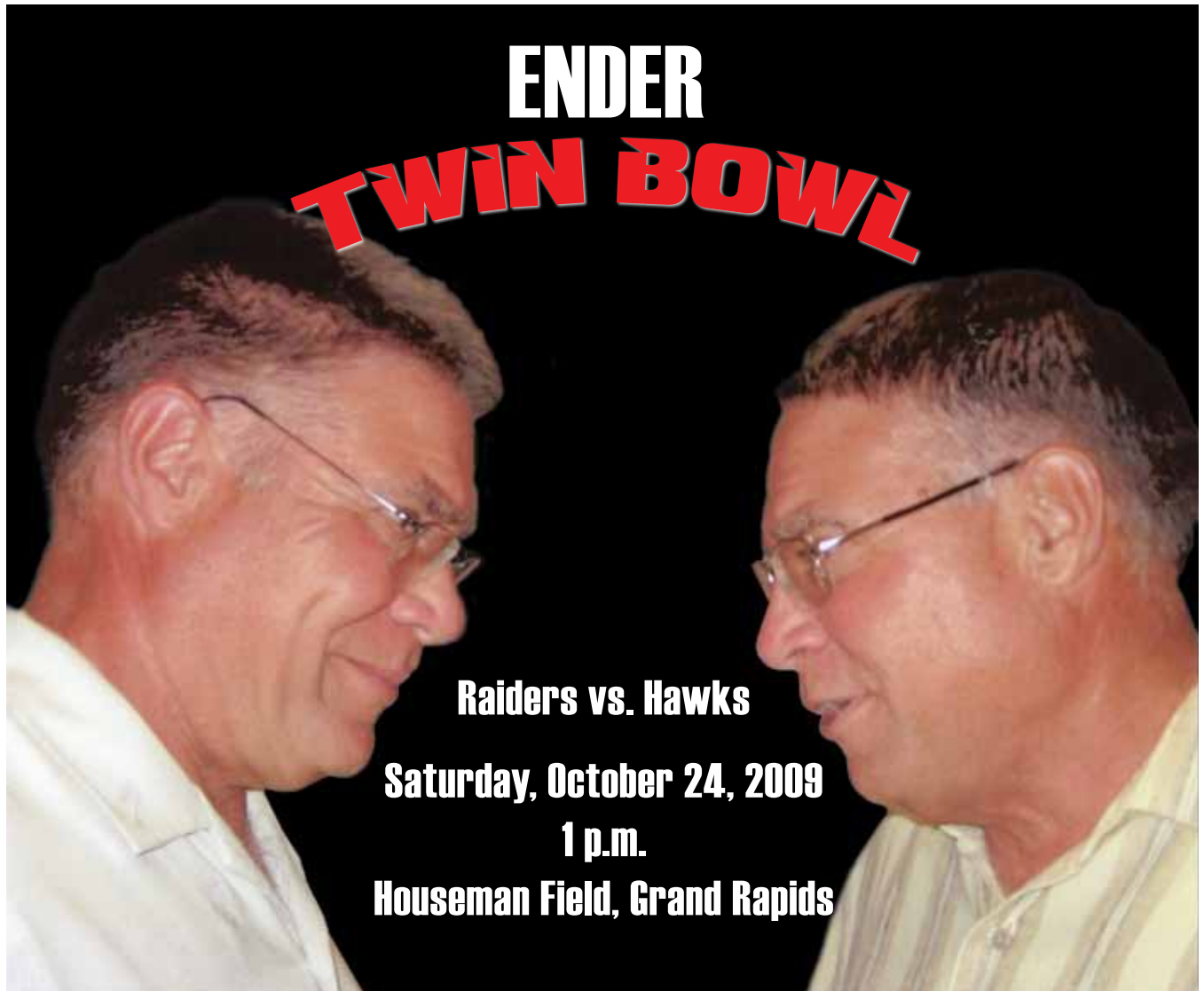

When GRCC hosts Harper College at Houseman Field on Saturday, October 24, there will be a little more at stake than regional bragging rights. That's because GRCC President Dr. Steven C. Ender will be sharing press box space with Harper President Kenneth Ender... his twin brother.

This unusual confrontation may well be the first time twin community college presidents have watched their football teams go head to head. It's not likely to be the last; GRCC and Harper both play in the Midwest Conference and will be regular season opponents for years to come.

So...is there a grudge to settle? A bet? A chance to finally prove which one mom liked best? Neither Ender is talking. At least not yet.

Game time is 2:00 p.m. And don't forget your popcorn.

For more information go to grcc.edu/twinbowl



The Days Are Just Packed

There's a lot happening at GRCC this fall, especially in October a month that culminates with the inauguration of Dr. Steven C. Ender as the college's ninth president. Here is a quick list of just a few of the big events scheduled for this month.

Through October 8 ArtPrize At GRCC

Regular building hours
Various locations
Free admission

Grand Rapids Community College is hosting three venues during the 2009 International ArtPrize competition:

- Bostwick Commons
- Learning Resource Center and Applied Technology Center Patios
- The Heritage Restaurant Patio
(GRCC Student Life, located in the Student Community Center off of Lyon Street, is also serving as a voter registration site.)

For more information visit www.grcc.edu/artprize

October 9, 16, 23, 30 GRCC Computer Club

1:00 - 4:00 p.m.
Lab 217, ATC
Club membership \$50 per year (with scholarship support available)

An opportunity for individual and peer learning, information sharing and/or private computer and Internet use for individuals 45 and over. For more information contact Mike Faber at (616) 234-3483 or mfaber@grcc.edu

October 9, 16, 23, & 30 Senior Health Club

Friday mornings 9:00-10:00 a.m.
Grand Rapids Community College
Gerald R. Ford Fieldhouse
Room 304
\$30 donation suggested

Program available to Kent County residents 60 and older. Weekly sessions led by a Masters-prepared Wellness Educator and Certified Personal Trainer.

Program participation is limited to 25 persons. For more information or to register contact Continuing Education at (616) 234-3400 or go to www.grcclearn.com and click on Older Learner Center.

October 12-14, 2009 GRCC Social Science Department's Inaugural History of Gender and Sexuality Symposium

9:30 a.m.-3:30 p.m. Daily
Calkins Science Center
Room 348/Auditorium
Free admission

This symposium will focus on the spectrum of gender and sexuality and their historical construction and significances. It will include a series of speakers, panel discussions, and other events.

Interested members of the community are encouraged to attend this free event. For questions or those wishing to bring a large group can contact Professor Susan Williams at (616) 234-4418 or e-mail her at swilliams@grcc.edu

October 13 Life History Club

1:00-3:00 p.m.
Grand Rapids Community College
Wisner-Bottrall Applied
Technology Center
Club membership \$30 per year
(with scholarship support available)

For individuals 45 and over. To register contact Continuing Education at (616) 234-3400 or go online at www.grcclearn.com. For questions, contact Mike Faber at (616) 234-3483 or mfaber@grcc.edu

October 14

Diversity Lecture Series XV

Eric Alva, "Ending Don't Ask, Don't Tell"
7:00 p.m.
Fountain Street Church
Free admission

Alva is a decorated Iraq War veteran and the national spokesperson for the Human Rights Campaign fight to repeal the military's discriminatory LGBT policy. He is the recipient of a Purple Heart and has earned numerous civic awards.

On-campus parking is \$3.00. For more information, please call (616) 234-3390.

October 15 RX for Fun

An event to benefit GRCC nursing programs. See page 11.

October 18
Vocal Music Department
Concert
3:00 p.m.
St. Cecilia Music Center
Free admission

A concert presentation by the combined GRCC Choral Ensembles

October 19
Building Relationships,
Increasing Awareness,
Creating Opportunities: The
role of GRCC in meeting
future needs of the
Lakeshore Communities
A Community Conversation
By Invitation Only, 10:30 a.m.-noon
Midtown Center Auditorium
96 W. 15th St., Holland, MI 49423

October 20 & 21
Transformational Learning:
The GRCC Teaching and
Learning Experience
Uncovered
Student, Employee, Alumni and
Retiree Colloquium

We invite you to explore how GRCC has transformed the lives of current and former GRCC students and employees in two sessions:

CONFERENCE:
Tuesday, October 20, 2009, 10 a.m.-3 p.m.

Participants will present their paper, documentary, or artistic interpretation of how GRCC has transformed their lives or how they have transformed GRCC. As a member of the audience, you will vote on which finalist best represented transformational learning in their entry. Refreshments and lunch will be provided.
Wisner-Bottrall Applied Technology Center Banquet Rooms

PANEL AND AWARD CEREMONY:
Wednesday, October 21, 2009, 3-6 p.m.

Join Dr. Steven C. Ender as he discusses transformations through learning with employee, student, retiree, and alumni panelists.

First, second, and third place - including audience favorite - will be awarded and projects displayed.

Followed by a coffee and desert bar.
GRCC Spectrum Theater

October 19-22
Transformation...Seeing
Ourselves Differently
A week-long celebration of the inauguration of our ninth president, Steven C. Ender, Ed.D.

October 20
Transforming Community
Colleges in the Global Era
Community Colloquium
By Invitation Only
3:00-6:00 p.m.
Applied Technology Center
Banquet Rooms
151 Fountain NE

October 22
The Investiture of
Steven C. Ender, Ed.D.

Open To The Public
2:00 p.m.
Fountain Street Church
24 Fountain St. NE
Grand Rapids, MI 49503

Reception to follow.
For information:
www.grcc.edu/investiture

October 20
Fall Jazz Night
7:30 p.m.
St. Cecilia Music Center
Free admission

An evening of jazz presented by the GRCC Shades of Blue & Jazz Orchestra.

October 23
Kent Philharmonia
Orchestra's
Ghoul fest
Costume Contest begins at 6:30 p.m.
7:30 p.m. Concert
St. Cecilia Music Center

A Halloween Concert and Costume Contest for all ages.

October 24
Ender Twin Bowl I
See page 21

October 25
Instrumental Music
Department Concert
3:00 p.m., St. Cecilia Music Center
Free Admission

A concert presentation by the GRCC Instrumental Ensembles.

October 28-31
"Mauritius" by Theresa Rebeck
A GRCC Players presentation
All shows begin at 8:00 p.m.
Ticket price range: \$5 to \$10

GRCC Players open their 2009/2010 season with the play *Mauritius* by Theresa Rebeck. *Mauritius*: What would you give for two little pieces of paper? It depends on the two little pieces of paper...

Call (616) 234-3946 beginning October 12, 2009 for tickets and information.

October 30
StandOUT 2nd Annual
Halloween Bash
A community event
6:30-9:30 p.m.
Student Community Center 234N/234S
Multi-Purpose Room
\$3 entrance fee at the door.

October 30
LIFE TRANSITIONS:
Making the Right Choices

8:30-9:00 a.m.
Registration, networking,
continental breakfast

9:00 a.m.-noon
Interactive workshop
GRCC ATC
First Floor Banquet Rooms
Rooms 122 & 124
151 Fountain NE
\$35.00

(includes continental breakfast, materials,
and parking - scholarships available)

Senior Leadership Grand Rapids is offering this half-day workshop featuring career/life development expert Paul Phifer.

Free parking under the ATC entrance off Ransom.

Registration available through Continuing Education and Professional Development at (616) 234-3400 or online at www.grcclearn.com/OlderLearnerCenter

NEWSMAKERS



Lizz Kelly of Dayton, Ohio, is working from GRCC as a Michigan Campus Compact (MCC) AmeriCorps VISTA member to address poverty issues within the Grand Rapids community. Lizz will serve in the Academic Service-Learning Office with the goal of building mutually beneficial partnerships between community-based organizations and GRCC. Lizz is one of 22 MCC VISTAs serving communities across the state of Michigan.



Shanna Goff, Assistant Professor in Mathematics, attended her second session of the Kellogg Institute for Developmental Education at Appalachian State University, North Carolina. This is the Advanced Kellogg program for practitioners who want to further their scholarship into scholarship and research in developmental education. Shanna will then continue her practicum research in developmental math at GRCC.

AWARDS AND HONORS

GRCC has earned the Award for Energy Stewardship from Energy Education for its ongoing energy conservation and management program. The award was announced by **Dr. William S. Spears**, CEO and Founder of Energy Education who indicated the college saved 12,378,664 kWh over the past 15 months — the equivalent of 4,241 metric tons of carbon dioxide emissions being prevented, 761 cars being removed from the road, or 108,486 pine trees being grown for 10 years.



Maryann Lesert, Assistant Professor of English, recently published her first novel, “Base Ten.” She is currently on a Great Lakes book tour to publicize the work that was published by the Feminist Press as part of its Women and Science Series. More information about the tour can be found at www.maryannlesert.com



Shultz

GRCC was named this year’s winner of the Special Project Award by the Michigan Association of Continuing Education and Training (MACET) for the college’s work in training disabled and/or ex-offenders in green construction. **Phil Greene**, a Training Solutions program manager, and **Brian Shultz**, GRCC Construction Trades Manager, took the lead in developing a series of classes to give students the skills needed for jobs in the green construction industry. GRCC is one third of a unique partnership with Goodwill industries and Habitat for Humanity of Kent County.



Greene

AWARDS AND HONORS



GRCC football coach **Tony Annese** was the keynote at a USA Football Coaching School clinic in Ann Arbor. Annese addressed a group of volunteer coaches who work mostly with 9-12 year old players.



Lochan



Moody

Jeanette Lochan and **Laura Moody**, professors in the GRCC Nursing Department, have been instrumental in ensuring the continuing success of the UPNDC (Union of Prospective Nurses in a Diverse Community) mentoring program. Many of the mentors Lochan and Moody selected were nurses and/or former GRCC grads.



Mindy Firlan, director of the GRCC Academic Learning Center, and **Mike Schavey**, associate director of the Center, are finalists for the Dynamic Duo Leadership Award to be presented by the Young Nonprofit Professionals Network (YNPN), an organization that provides support, education and networking to people working in the nonprofit sector.

PROGRAMS



Foster



Kampmueller



Hesse

A team of science faculty — including **Laurie Foster**, **Elaine Kampmueller**, **Sarah Krajewski**, **Bill Faber**, and **Joe Hesse** — are working with KISD high schools to articulate college sciences curriculum with state high school sciences standards.

PROGRAMS



Biology professor **Paul Krieger** has produced a series of books using visual analogies to aid in teaching human anatomy and physiology. The books are available locally as well as on line. The titles: “A Visual Analogy Guide to Human Anatomy;” “A Visual Analogy Guide to Human Physiology;” “A Visual Analogy Guide to Human Anatomy & Physiology.”



Greg Forbes, Biology Professor, is continuing his research of the use of plastinated cadavers and digital imaging technology to enhance cadaver use in the Anatomy and Physiology classroom.



Krajewski

Science faculty members **Laurie Foster**, **Sarah Krajewski**, and **Tim Hoving** are researching concept-based curricular approaches to teaching Biology to non-majors. The group is strengthening the BI 101 course’s approaches to interactive learning with the intent of developing for the learner’s understanding and appreciation for life sciences in the everyday world.



Nikki Banks, Criminal Justice assistant professor, had students conduct their own evidence-based behavioral research program. Students worked with Heath Chelesvig from Institutional Research to create and conduct a survey and analyze the results.



Nordman

Students in **Deb Nordman’s** Radiology Tech class joined forces with **Charlie Olawsky’s** Culinary Education students to discover the finer points of fish skeletal systems. The Rad Tech students learned positioning techniques and proper kV-MV settings for accurate imaging in bony structures. The culinary students came away with sharper deboning skills.



Olawsky



The GRCC Irish Studies Program recently hosted the first annual Peace and Reconciliation Conference. **Robert Hendershot**, Assistant Professor of History and Director of the Irish Studies Program, developed and led the event. The conference featured a number of speakers involved in the peace and reconciliation work in their homeland. Additionally, two guests addressed the conference by video: famed hunger-striker Paddy Ryan and Nobel Peace Prize Laureate John Hume.

GRCC Foundation Board

David Custer
Chairperson
Custer Workplace Interiors

Jeff Gietzen
Vice Chairperson
Midwest Capital Advisors, LLC

Douglas M. Klein
Treasurer
Northern Trust Bank

Glen Borre
Secretary
Miller Johnson

Robert Partridge
Assistant Treasurer
Vice President of Business & Financial Services
Grand Rapids Community College

Andy Bowne, Ed.D.
Executive Director
Associate Vice President for College Advancement
Grand Rapids Community College

Olivia Margo Anderson
GRCC Board of Trustees

George Aquino
J.W. Marriott Grand Rapids

David C. Bottrall
Tassell-Wisner-Bottrall Foundation

Jeremy Christiansen
GRCC Student Congress

Michael Despres
Wachovia Securities, Inc.

Beverly Drake
ACSET

Steven C. Ender, Ed.D.
President
Grand Rapids Community College

Thomas J. Heiks
Fifth Third Bank

Ellen M. James
GRCC Board of Trustees

Mike Lloyd
The Grand Rapids Press, Retired

Walter Lodes, Jr.
GRCC Alumni Assn

James E. Marosi
Wachovia Securities, Inc.

Richard A. Morton
Greenridge Realty

Ana L. Ramirez-Saenz
La Fuente Consulting

Shawn Ulreich
Spectrum Health

Fred van Hartesveldt
GRCC Faculty Association

Dan Webb
Meijer, Inc.

George A. Wolfe, Ph.D.
Steelcase, Inc.

James M. LaFleur
Director Emeritus
LaFleur & Godfrey, Inc.

GRCC Board of Trustees

Olivia Margo Anderson
Chairperson

Michael A. Stearns, Ed.D.
Vice Chairperson

Janice L. Maggini
Secretary

Ellen M. James
Treasurer

Terri A. Handlin
Trustee

Richard P. Ryskamp, M.D.
Trustee

Richard W. Verburg
Trustee

Steven C. Ender, Ed.D.
President

Survey Says!

Results of our Spring 2009 survey will be published in our Winter issue. Stay tuned.

DIVERSITY

2009-2010

Lecture Series XV

October 14, 2009



Eric Alva

Iraq War Veteran, LGBT Rights Activist

"Ending Don't Ask, Don't Tell"

Eric Alva was the first American wounded in Iraq and the war's first Purple Heart recipient. Alva is the national spokesperson for the Human Rights Campaign fight to repeal the military's discriminatory LGBT policy. He joined Congressman Martin Meehan in introducing the Military Readiness Enhancement Act, a bill designed to repeal the military's "Don't Ask, Don't Tell" policy.

November 11, 2009



Prince Cedza Dlamini

Humanitarian, Social Entrepreneur

"Global Forgiveness and Connectedness"

Cedza Dlamini's vision is to create a unified global order of young leaders working to collectively address world problems, such as HIV/AIDS, poverty, hunger and illiteracy. He founded the Ubuntu Institute for Young Social Entrepreneurs, to achieve the Millennium Development Goals, the United Nation's eight point strategy to eradicate poverty, hunger and disease in Africa.

December 9, 2009



Morris Dees

Civil Rights Activist, Attorney, Author

"With Justice for All"

Civil rights and diversity speaker Morris Dees is the co-founder of the Southern Poverty Law Center, a non-profit group specializing in lawsuits involving civil rights violations, domestic terrorism, and hate-motivated crimes today. He focuses his attention on anti-government militias. In his brilliant expose Gathering Storm: America's Militia Threat, Dees explains the dangers these groups represent.

February 10, 2010



Angela Davis

Human Rights Activist, Author

"Frameworks for Social Justice"

Angela Davis is known internationally for her ongoing work to combat all forms of oppression from the Civil Rights Movement through today's injustices. Over the years, as a student, teacher, writer, scholar, activist and organizer - and even prisoner - she has become a living witness to the historical struggles of two generations of American life. Davis is a tenured professor at the University of California Santa Cruz.

March 10, 2010



Brigitte Cazalis-Collins

Social Justice Activist

"The Front Lines of the War against Child Sex Trafficking"

Over the past twenty years, Brigitte along with her husband, Joseph Collins, have worked to bring world-wide attention to the tragic crisis of the sex trade. Each year more than one million women and children are kidnapped and sold into sex slavery. *Maiti Nepal*, founded by Brigitte and Joseph is a charitable organization based in Kathmandu, Nepal, formed in 1993 to combat the sex trafficking of women and children.

For more information, please call (616) 234-3390.

- Free and open to the public
- On-campus parking \$3.00 (with discount pass)
- Lectures begin at 7 p.m. at Fountain Street Church, 24 Fountain NE

Bob and Alecia Woodrick
Diversity Learning Center

