

MN213

MACHINERY'S HANDBOOK



**STUDENT STUDY MANUAL FOR
CHALLENGE EXAMINATION**

Revised Fall 2008



Department: Apprenticeship Training
Course Title: MN-213 Machinery's Handbook

A. Course Description

Industrial workers learn to use the handbook to solve problems involving square roots, circle formulas, tapers, threads, oils, coolants, and steel fabrication.

B. Student Performance Objectives

1. Given a test on powers, roots, and reciprocals of numbers, the student will solve the problems with an accuracy of 90%.
2. Given a test on the area, radius, diameter, and circumference of a circle, the student will solve the problems with 90% accuracy.
3. Given a test on the chordal dimensions and segments of a circle, the student will solve the problems with 90% accuracy.
4. Given a test on spheres and spherical segments, the student will solve the problems with accuracy of 90%.
5. Given a test on formulas, the student will solve the problem by transposing numbers with 90% accuracy.
6. Given a test on areas and volumes of geometric figures, the student will solve the problems with 90% accuracy.
7. Given a test on angles and functions of angles, the student, using a trigonometric function table, will solve the problems with 90% accuracy.
8. Given a test involving the solution of right triangles and oblique triangles, the student, using trigonometric tables and formulas, will solve the problems with accuracy of 85%.
9. Given a test on taper per inch and foot, the student will solve the problems with 85% accuracy.
10. Given a test on machine parts, the student will give allowance and tolerance for each part with 90% accuracy.

11. Given a test on screw thread, the student will identify screw threads with 90% accuracy.
12. Given a test on cutting speeds and feeds for machining of metal, the student will solve the problems with accuracy of 90%.

C. Testing Conditions/Recommended Materials

1. Machinery's Handbook, 27th edition
2. Calculator
3. Machinery's Handbook Guide

D. Test Norm Levels

	Points Per Problem	Total Points Needed
25 Questions	4	72

E. Test Format and Procedures

The test is to be completed within a three-hour period. Multiple choice format. Because the test is an open-book format, it is not necessary to memorize any of the formulas or calculations. However, because time is limited, you should have a good understanding of where material is located in the Handbook and how to apply the formulas.

Name _____

Date _____

1. Using a Cutting Speed of 80 SFM, what is the correct RPM (revolutions per minute) to turn a shaft on a lathe that measures 2.5 inches in diameter?
2. What is the correct RPM and IPM (inches per minute) for a 4 flute, $\frac{1}{2}$ diameter end mill using a Cutting Speed of 200 SFM, and a chip load of .004 per tooth?
3. What is the correct tap drill for $\frac{1}{4}$ -20 NC tapped hole?
4. What is the correct clearance drill for a $\frac{3}{8}$ SHCS (normal fit)?
5. What diameter is a "Q" drill?
6. What is the diameter of a circle with an area of 33.18307 in² ?
7. What is the TPI (taper per inch) of a 12 inch long shaft that measures .625 at one end and 1.350 at the other end?

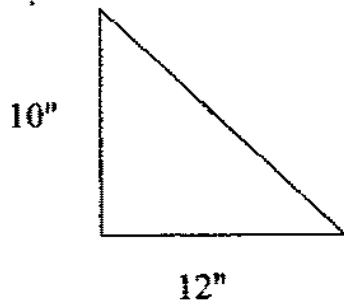

Area = _____

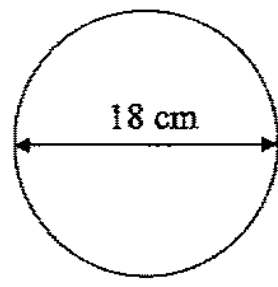

Area = _____

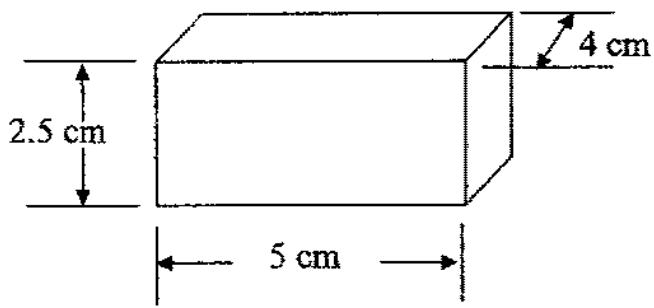

Volume = _____

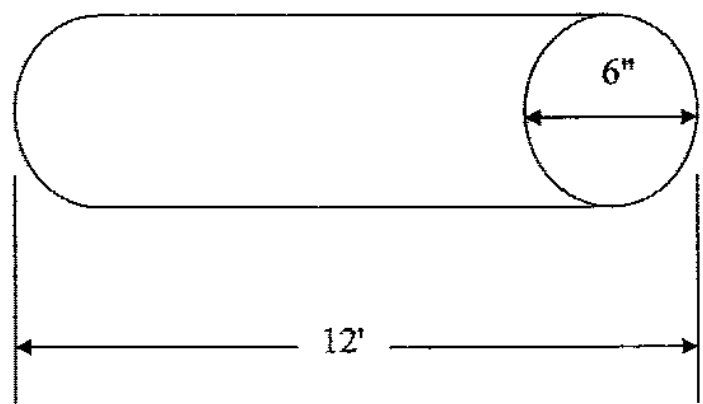

Volume = _____

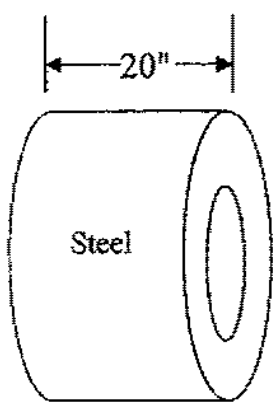

O.D. = 4.5'

I.D. = 18"

Volume = _____

Weight (lbs) = _____

Right Angle Trigonometry

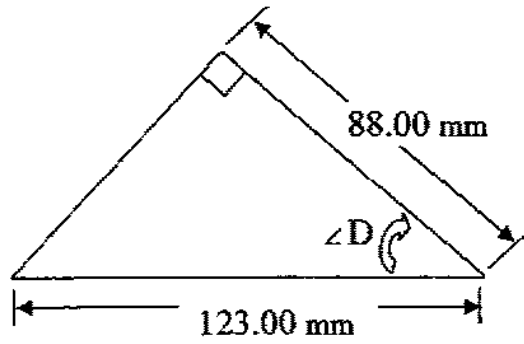

Determine $\angle D$ _____

Law of Sines

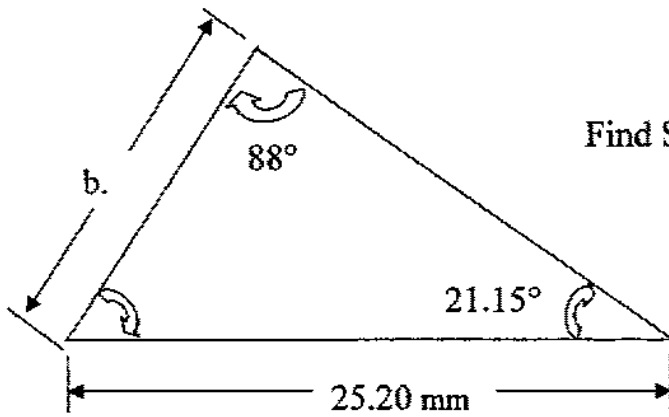

Find Side b _____

Handbook Questions – Answers

1. 128 RPM (\pm depending on formula used)
2. 1600 RPM (\pm depending on formula used)
25.6 IMP (\pm depending on calculated RPM)
3. #7 drill
4. 13/32 drill
5. .332 inch diameter
6. 6.5 inch diameter
7. .0604 inches
8. Area of triangle = 60 in²
9. Area of circle = 254.469 cm²
10. Volume of rectangle = 50 cm³
11. Volume of cylinder = 4071.5 in³ or 2.36 ft³
12. Volume of coil = 40,715 in³ or 23.6 ft³
Weight of coil = 11,563.07 lbs (\pm depending on variable used for weight per unit)
13. Angle D = 44.320° or 44° 19' 13"
14. Side b = 9.098 mm