

MIN114

**MACHINE TRADES BLUEPRINT
READING**



**STUDENT STUDY MANUAL FOR
CHALLENGE EXAMINATION**

Revised Fall 2008

DEPARTMENT: Manufacturing/Apprenticeship

COURSE TITLE: MN-114, Machine Trades Blueprint Reading

A. Course Description

A study of lines, views, dimensions, and notes with some sketching as it is used in the machine trades.

B. Student Performance Objectives

The student will be able to answer questions pertaining to a part print at a level of 70% correctness:

1. When two views are shown.
2. When object lines, hidden edge lines, extension lines, and dimension lines are shown.
3. When three views are shown in proper arrangement.
4. That includes dimension, finish marks and notes.
5. That includes screw threads and the necessary dimensions.
6. That includes full and half section drawings.

C. Testing Conditions

The college will provide the necessary material.

D. Test Norm Levels

	Points Per Problem	Total Points Needed
Support	2	16
Slide	1	19
Base	1	30

E. Test Format and Procedures

The test is to be completed within a two hour period. See Test Norm Levels (D) for specific types of questions.

F. Sample Problems

1. Tee Slide
2. Cross Slide
3. Idler Shaft Support

TEE SLIDE

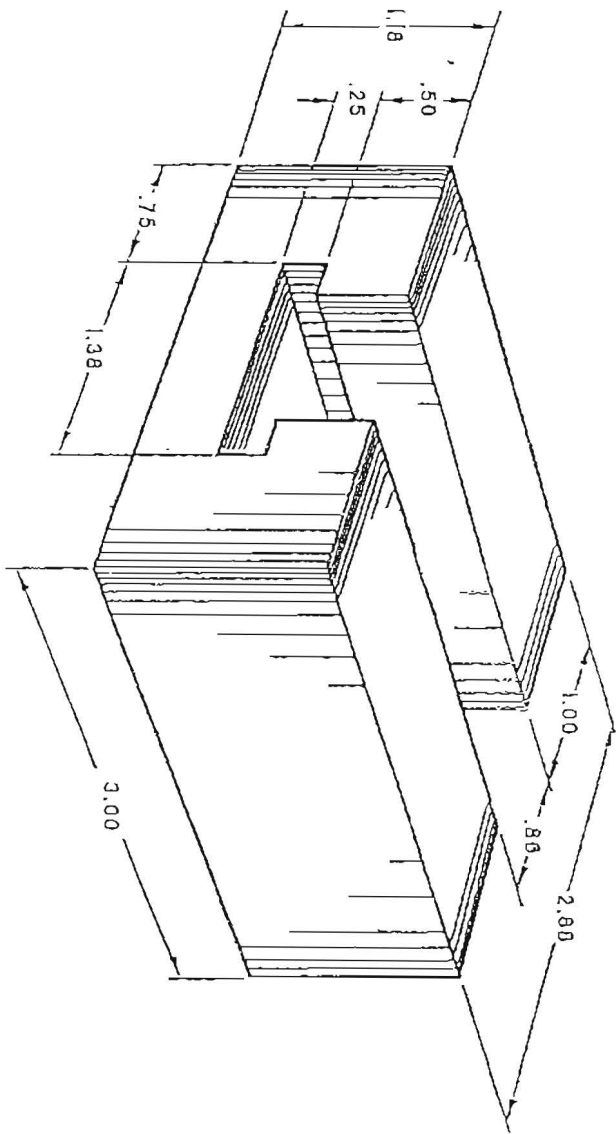

Name _____

SKETCHING ASSIGNMENT FOR TEE SLIDE

- ① MAKE FREEHAND SKETCHES OF THE FRONT, TOP, AND RIGHT SIDE VIEWS
- ② DIMENSION THE VIEWS

SUGGESTIONS

- ① CENTER THE SKETCHES ON THE SQUARED SECTIONS
- ② ALLOW 3/4" BETWEEN THE VIEWS

CROSS SLIDE

NO. REQD 6

ORDER NO. 76-42

MATL GRAY CAST IRON

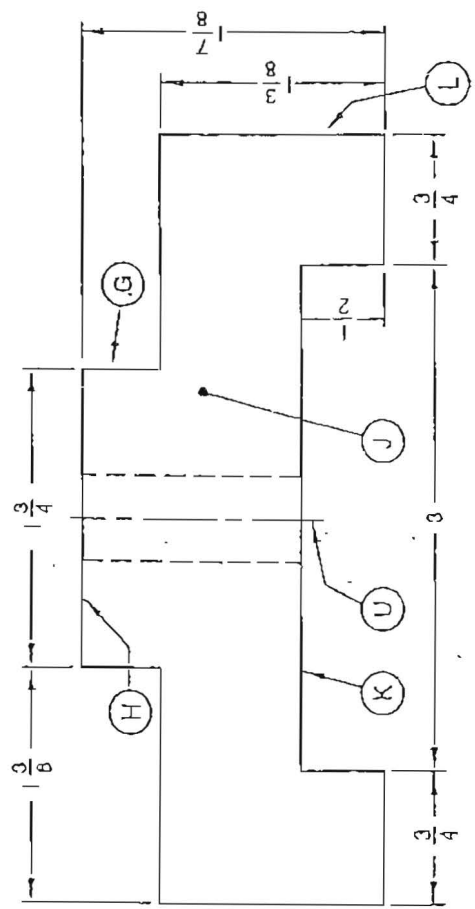
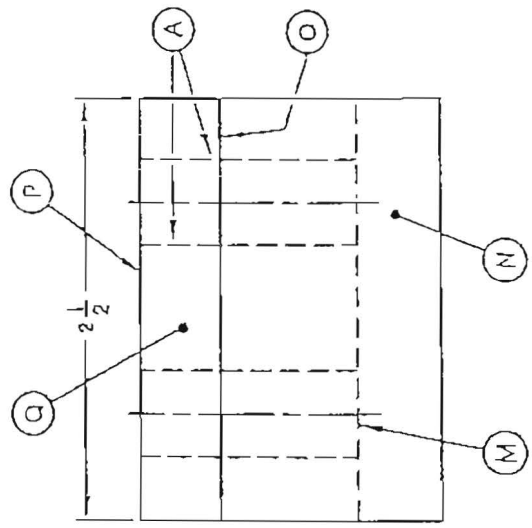
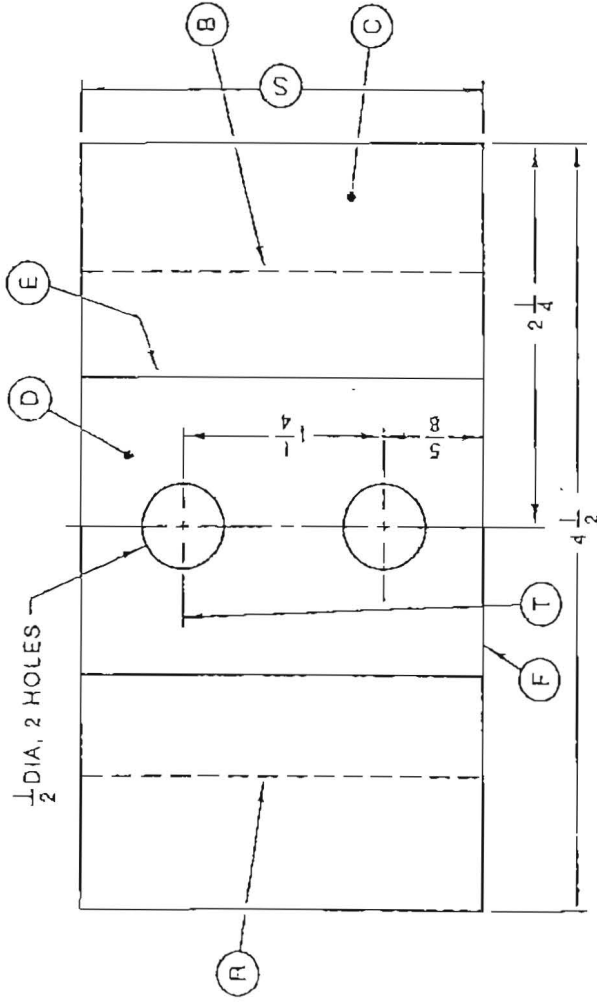
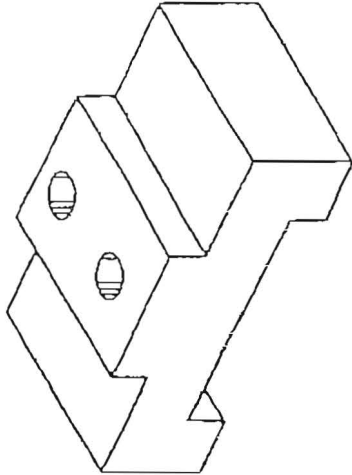

CROSS SLIDE

- | | | | |
|---|--|-----------|-----------|
| 1. What material is used for the Cross Slide? | 13. What line in the side view represents surface (D) in the top view? | 1. _____ | 13. _____ |
| 2. How many pieces are required? | 14. What is the diameter of the holes? | 2. _____ | 14. _____ |
| 3. What is the overall width (length) of the Cross Slide? | 15. What is the center-to-center dimension of the holes? | 3. _____ | 15. _____ |
| 4. What is the order number? | 16. How far is the center of the first hole from the front surface of the slide? | 4. _____ | 16. _____ |
| 5. What is the overall height of the Cross Slide? | 17. Are the holes drilled all the way through the slide? | 5. _____ | 17. _____ |
| 6. What are the lines marked (A) and (B) called? | 18. What is the width of the slot shown in the front view? | 6. _____ | 18. _____ |
| 7. What do the lines marked (A) represent? | 19. What is the height of the slot? | 7. _____ | 19. _____ |
| 8. What two lines in the top view represent the slot shown in the front view? | 20. Determine dimension (S) . | 8. _____ | 20. _____ |
| 9. What line in the right side view represents the slot shown in the front view? | 21. What is the width of the projection at the top of the slide? | 9. _____ | 21. _____ |
| 10. What line in the front view represents surface (Q) in the right side view? | 22. How high is the projection? | 10. _____ | 22. _____ |
| 11. What line in the front view represents surface (D) in the top view? | 23. What kind of line is (M) ? | 11. _____ | 23. _____ |
| 12. What line in the top view represents surface (J) in the front view? | 24. What kind of line is used at (O) and (P) ? | 12. _____ | 24. _____ |

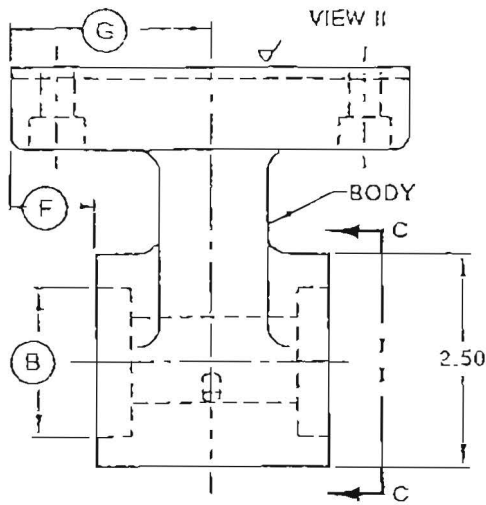

SECTION
B-B
(ROTATED
45° CW)

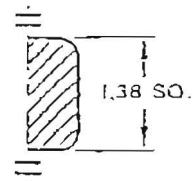

Ø 1.000
2 x L Ø 1.750
Ø 1.749
±.41

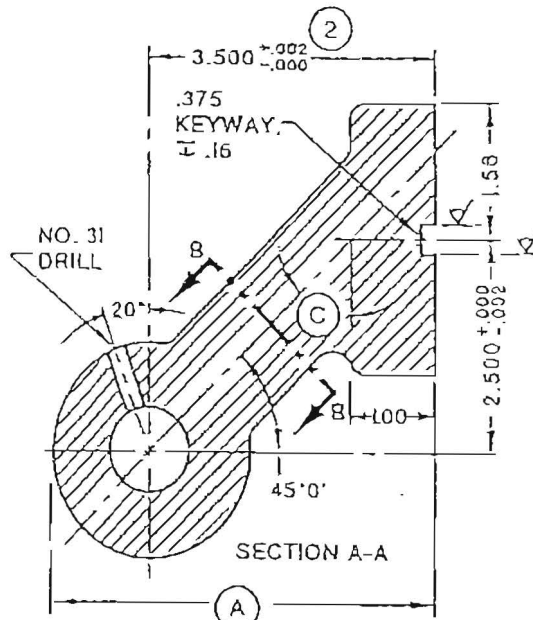
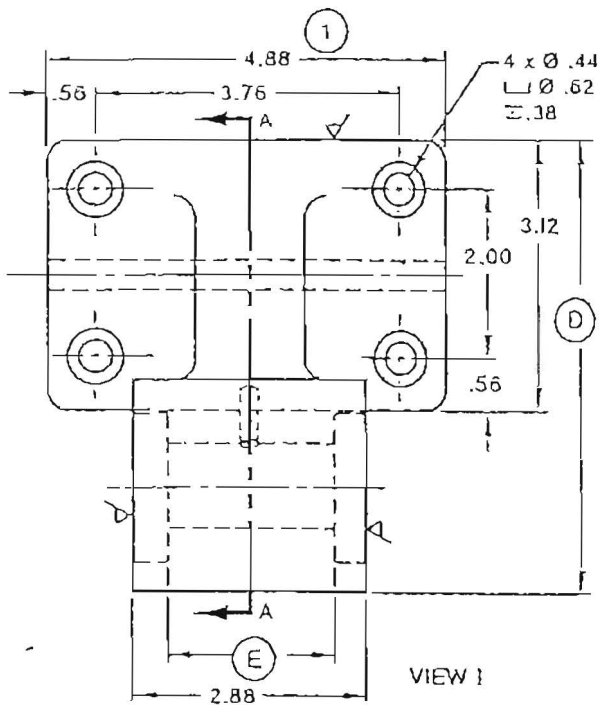
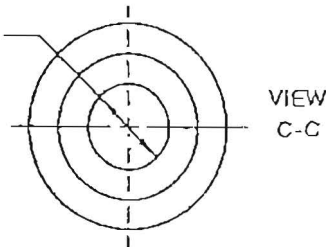

ALL FILLETS AND
ROUNDS R.25

MATL C.I.	QTY 125	ORDER NO. E S - 10 - 210				
DWG. BY H.G.P.	CK. T.P.O.	APPVD. C.T.O.				
UNLESS OTHERWISE SPECIFIED TOLERANCES ON DIMENSIONS ARE: DECIMAL DIMENSIONS ± .01" (TWO-PLACE) ± .002" (THREE-PLACE) FRACTIONAL DIMENSIONS ± 1/64 ANGULAR DIMENSIONS ± 10'			②	WAS 3.270	J.E.F.	
			①	WAS 4 7/8	J.E.F.	
			NO.	CHANGE	DATE	BY
			IDLER SHAFT SUPPORT			

IDLER SHAFT SUPPORT

1. Give the specifications for the counterbored holes.
2. How deep is the counterbored portion of the holes?
3. Give the specifications for the flat keyway.
4. What size are the fillets and rounds?
5. What size drill is used for the hole drilled at an angle?
6. Give the tolerance on the 20° dimension.
7. Compute angle (C) from dimensions given on the drawing.
8. Give the maximum diameter for the 1" hole.
9. What is the largest size to which diameter (B) can be bored?
10. How are the machined surfaces indicated?
11. What type line shows where Section A-A is taken? In what view?
12. Determine dimensions (A) and (D).
13. Determine from Section B-B what material is required.
14. How wide and thick is the body?
15. Indicate what two changes were made from the original drawing.
16. Determine nominal dimension (E).
17. Compute maximum dimension (F).
18. What is upper limit of dimension (G)?
19. Why is section A-A a full section?
20. Show the section linings for aluminum and for steel.
21. Identify (a) the system of dimensioning and (b) the classification of the unspecified tolerances.
22. Change the tolerances as follows: two-place decimal dimensions $\begin{smallmatrix} +.02 \\ -.00 \end{smallmatrix}$; three-place $\begin{smallmatrix} +.003 \\ -.000 \end{smallmatrix}$; and angular $\begin{smallmatrix} -10 \\ -0 \end{smallmatrix}$.
Then compute the upper and lower limit for angle (C) and dimensions (A), (D), (E), (F), and (G).

1. _____

2. _____

3. _____

4. _____ 5. _____

6. _____ 7. (C) = _____

8. _____ 9. _____

10. _____

11. _____

12. (A) = _____ (D) = _____

13. _____

14. _____

15. _____

16. (E) = _____

17. (F) = _____

18. (G) = _____

19. _____

20. Aluminum Steel

21. (a) _____

(b) _____

22. Angle (C) = _____

(A) = _____

(D) = _____

(E) = _____

(F) = _____

(G) = _____

Student's Name _____

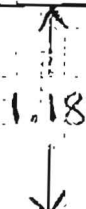
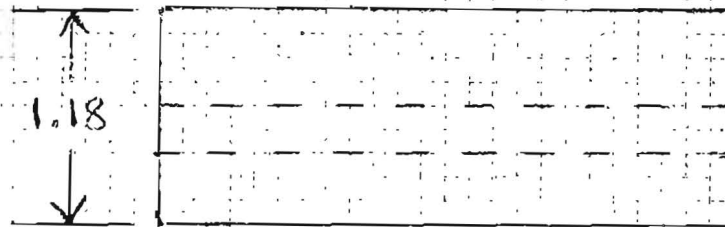
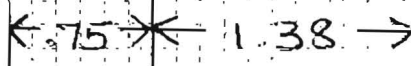
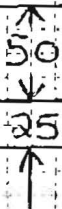
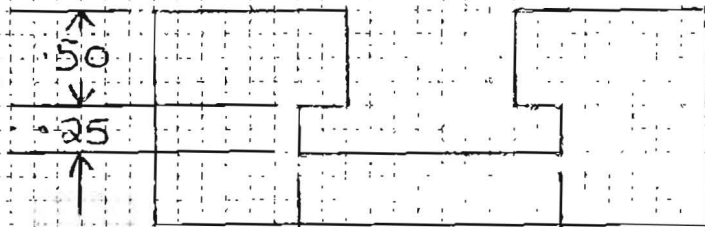
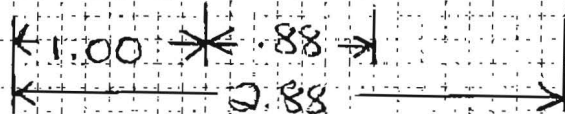
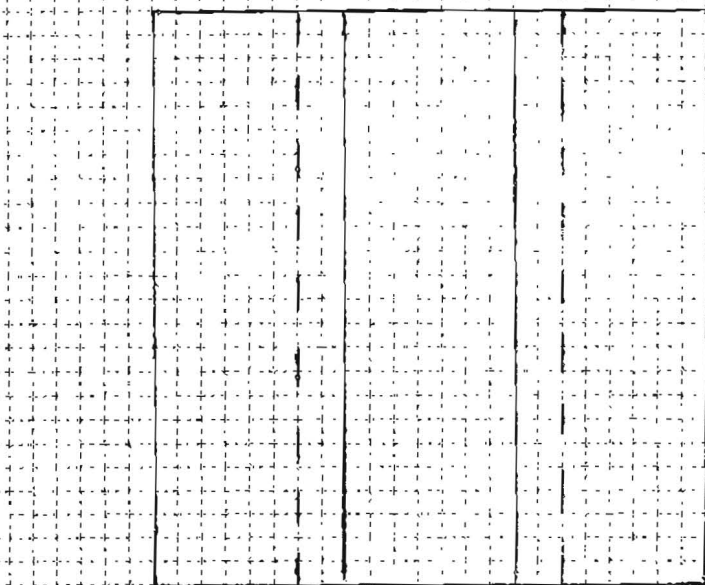

SKETCHING ASSIGNMENT FOR TEE SLIDE (BP-31B)

- ① MAKE FREEHAND SKETCHES OF THE FRONT, TOP, AND RIGHT SIDE VIEWS
- ② DIMENSION THE VIEWS

SUGGESTIONS

- ① CENTER THE SKETCHES ON THE SQUARED SECTIONS
- ② ALLOW 3/4" BETWEEN THE VIEWS

IDLER SHAFT SUPPORT

1. Give the specifications for the counterbored holes.
2. How deep is the counterbored portion of the holes?
3. Give the specifications for the flat keyway.
4. What size are the fillets and rounds?
5. What size drill is used for the hole drilled at an angle?
6. Give the tolerance on the 20° dimension.
7. Compute angle (C) from dimensions given on the drawing.
8. Give the maximum diameter for the 1" hole.
9. What is the largest size to which diameter (B) can be bored?
10. How are the machined surfaces indicated?
11. What type line shows where Section A-A is taken? In what view?
12. Determine dimensions (A) and (D).
13. Determine from Section B-B what material is required.
14. How wide and thick is the body?
15. Indicate what two changes were made from the original drawing.
16. Determine nominal dimension (E).
17. Compute maximum dimension (F).
18. What is upper limit of dimension (G)?
19. Why is section A-A a full section?
20. Show the section linings for aluminum and for steel.
21. Identify (a) the system of dimensioning and (b) the classification of the unspecified tolerances.
22. Change the tolerances as follows: two-place decimal dimensions $\begin{smallmatrix} .02 \\ - .00 \end{smallmatrix}$; three-place $\begin{smallmatrix} .003 \\ - .000 \end{smallmatrix}$; and angular $\begin{smallmatrix} .10 \\ - .07 \end{smallmatrix}$.
Then compute the upper and lower limit for angle (C) and dimensions (A), (D), (E), (F), and (G).

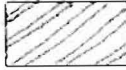
1. $4 \times \varnothing .44$, $4 \varnothing .62$
 $\nabla .38$
2. $.38$
3. $.375$, $\nabla .16$
4. $R.25$
5. $\# 31$
6. $\pm 10'$
7. $\textcircled{C} = 45^\circ$
8. 1.002
9. 1.750
10. \checkmark
11. Cutting Plane Line, Front View
12. $\textcircled{A} = 4.75$ $\textcircled{D} = 5.31$
13. Cast Iron
14. 1.38 square
15. 4.88 was $4\frac{7}{8}$
 $3.500 \begin{smallmatrix} +.002 \\ -.000 \end{smallmatrix}$ was 3.270
16. $\textcircled{E} = 2.06$
17. $\textcircled{F} = 1.01$
18. $\textcircled{G} = 2.45$
19. Cutting Plane Cuts
Completely Through Object
20. Aluminum  Steel 
21. (a) Aligned Dimensions
(b) Bilateral Tolerances
22. Angle $\textcircled{C} = 45^\circ$ to $45^\circ 10'$ or 45° to 45.16°
 $\textcircled{A} = 4.75$ to 4.77
 $\textcircled{D} = 5.31$ to 5.33
 $\textcircled{E} = 2.06$ to 2.08
 $\textcircled{F} = 1.0$ to 1.02
 $\textcircled{G} = 2.44$ to 2.46